

WET BARREL HYDRANT HEADERS

Fire hydrants are an essential part of any firefighting system. They enable the distribution of large volumes of firefighting water very quickly across a site.



PRODUCT DETAILS

Knowsley SK wet barrel pillar hydrants offer a cost-effective and low maintenance solution to your hydrant needs where freezing is not a consideration.

Where freezing is to be considered, please see our comprehensive range of internally valved pillar hydrants.

We know fire. We know safety. We know you.

Established in 1896, Knowsley SK Ltd. has an enviable reputation for manufacturing quality fire fighting equipment and systems for high value asset protection that can be relied upon when danger strikes.

Knowsley SK Ltd
Centrepoint
Marshall Stevens Way
Trafford Park
Manchester M17 1AE | UK
t +44 (0)161 872 7511
f +44 (0)161 848 8508

sales@knowsleysk.co.uk
spares@knowsleysk.co.uk

www.knowsleysk.com

Registered in England No. 1789152
VAT No.: 383475131

DESIGN

Knowsley SK's experienced engineers incorporate their many years' knowledge and expertise in designing and manufacturing hydrants to suit our clients' specifications.

Common considerations include: size, layout, materials, and fittings / accessories.

Design work can also include production of General Arrangement and Isometric Drawings, Bills of Materials, and Spares Lists on request.

SIZE

Knowsley SK wet barrel hydrants can be manufactured in various sizes, from 3"(80mm) NB single outlet standpipes and spools, to very large, high volume outlets to serve the largest fire fighting equipment on the market.



Figure 1 Bespoke Wet Barrel Hydrant Header Layout

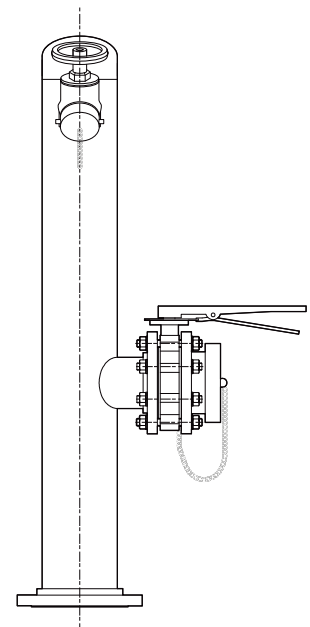
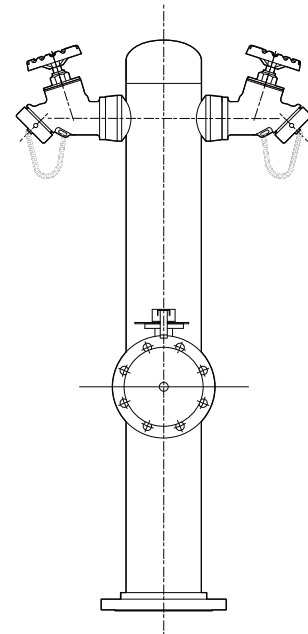

Figure 2 Typical Wet Barrel Hydrant Header

PRODUCT MATERIALS

Our standard materials for wet barrel headers are:

- Carbon Steel
- Gunmetal
- Stainless Steel

We can, however, manufacture wet barrel headers from any commercially available material on request.

LAYOUT

As an O.E.M., we are able to offer complete flexibility in the layout of our hydrants.

According to specifications, we can furnish any combination of the following:

- Header inlet size and type
- Number of outlets
- Size of outlets
- Position / orientation of outlets
- Flanged / threaded / symmetrical connections

ACCESSORIES

Knowsley SK hydrant headers can be equipped with a vast range of equipment. Accessories are listed below:

- Hose Valves & Connections
- Pressure Regulating Valves (PRVs)
- Pumper Valves & Connections
- Monitors



Figure 3 Variant including butterfly isolation and pumper valves, and (non-pressure regulating) globe valves.

Monitor may also be top-mounted.

