



FoamTronic®

VARIABLE FREQUENCY DRIVEN
FOAM MIXING TECHNOLOGY

SYSTEM START

Foam mixing will start when a set minimum water flow is detected. The system allows two preset mixing rates. The mixing rate will be selected by means of a signal from the customer's control panel.

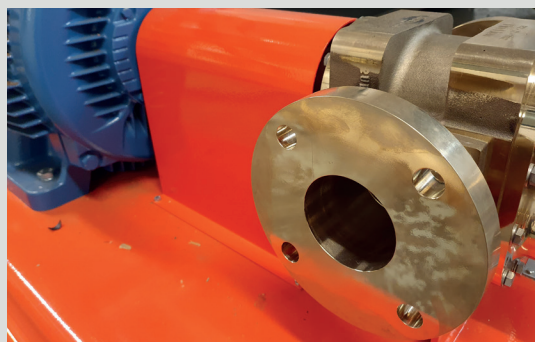

SELF-DIAGNOSTICS

The VFD Foamtronic continuously monitors the following:

- + Power available
- + Condition of flow meters
- + Condition of frequency drive
- + The PLC



SYSTEM CAPACITY

Due to the ability to control the speed of the foam pump, the system has a very wide working range. The maximum water pressure can go up to 16 bar. The standard models have the following working ranges:

PREMIX FLOW @ MIXING RATIO 3%

Model number	Max system power (kW)	Min flow (lpm)	Max flow (lpm)
FT-VFD1	11	200	4.900
FT-VFD2	15	200	7.050
FT-VFD3	30	350	14.500
FT-VFD4	45	500	22.600
FT-VFD5	75	1000	44.000

The table is based on the following parameters:

- + 10 - 16 bar outlet pressure
- + 3% foam mixed at 3.1%

BACK-UP OPTION

The system has the ability to communicate with, and control a back-up Foamtronic unit, increasing the operational reliability.



THE VARIABLE FREQUENCY DRIVEN (VFD) FOAMTRONIC IS AN ELECTRONIC FOAM PROPORTIONING SYSTEM WHICH ACCURATELY PROPORTIONS FOAM CONCENTRATE INTO WATER, BASED ON THE ACTUAL FIREWATER DEMAND OF THE SYSTEM. IT IS DESIGNED TO COVER A WIDE RANGE OF FOAM SYSTEM DEMANDS.

BENEFITS

- + FM APPROVED FOAM PUMP
- + NFPA11 COMPLIANT
- + PLUG AND PLAY
- + SYSTEM TEST WITHOUT MIXING WATER AND FOAM
- + NO PRESSURE LOSS IN FIREWATER PIPE
- + COMPATIBLE WITH ALL FOAM CONCENTRATE TYPES

TEST WITHOUT MIXING

To comply with the NFPA 11 standard, the operation of a foam extinguishing system must be tested annually with a live test. A large amount of foam concentrate is used for this test. This is not only harmful for the environment, but also expensive for the owner. It is not only the purchase value of the foam concentrate, but also the additional costs as the foam must be collected, and disposed of correctly to satisfy the environmental requirements.

The FoamTronic VFD system is NFPA 11 compliant and can be tested without the need of mixing firewater and foam concentrate. The system is supplied as standard, as pre-build package or as individual components or as shown below.



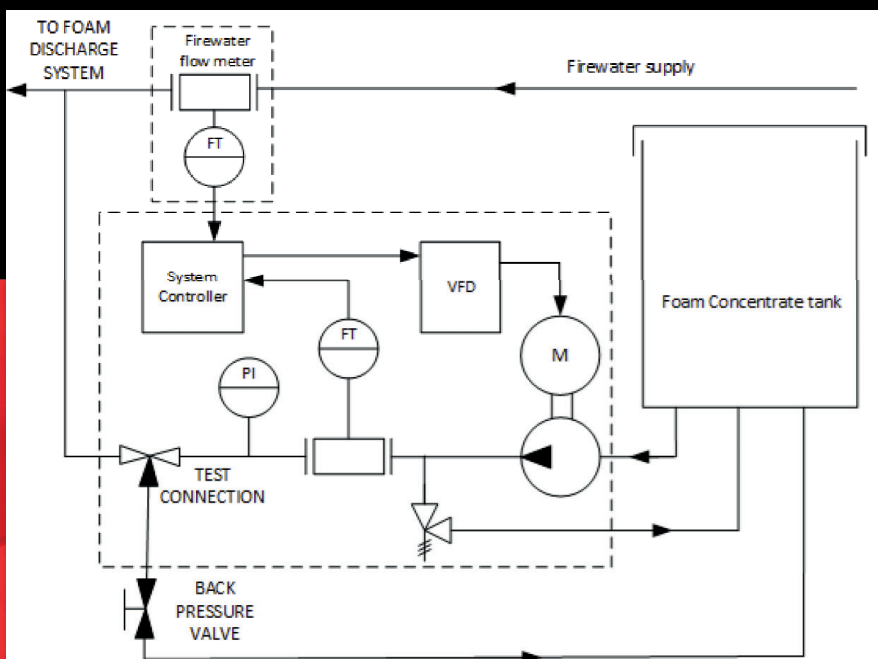

SYSTEM P&ID



HIGH PRECISION PROPORTIONING

The accurate mixing of foam concentrate and water is achieved by the continuous monitoring of the firewater and foam concentrate flows, using electromagnetic flowmeters and a real-time adjustment of the speed of the foam pump. The accuracy and stability of the system is based on the combination of specially selected components and a unique control system with state-of-the-art logic developed specifically for FoamTronic. The control system records all process values and alarms during operation or test which are available via a simple user friendly interface.

When compared to a traditional mechanical proportioner the user has the added benefit of being able to save money on the foam usage due to the high accuracy of controllable consistent proportioning.

FOAMTRONIC VFD	VS.	MECHANICAL PROPORTIONER
	FLOW RATE	
12 000		12 000
	MIXING RATIO	
3.1%		3.9%
	EXTINGUISHING TIME	
30 min		30 min
	FOAM TANK	
11.2 m ³		14.0 m ³
	*PRICE OF FOAM €5 000/M ³	
€56 000		€70 000
Saving of €14 000		

* This is an example and not an actual price.



Centrepoint
Marshall Stevens Way
Trafford Park
Manchester M17 1AE
United Kingdom

+44 (0) 161 872 7511
sales@knowsleysk.co.uk
www.knowsleysk.co.uk



Huifakkerstraat 22
4814 PE Breda
The Netherlands

+31 (0) 76 54 87 000
systems@saval.nl
www.saval.nl

Due to continual product developments and improvements, we reserve the right to change or modify the published performance characteristics without notice.